

## Type FM

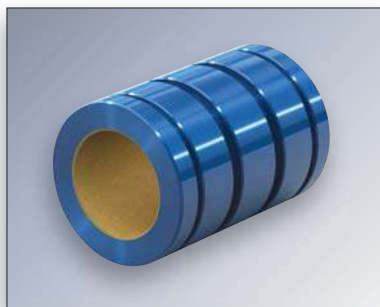

Aluminium anodisé  
Revêtement intérieur teflon

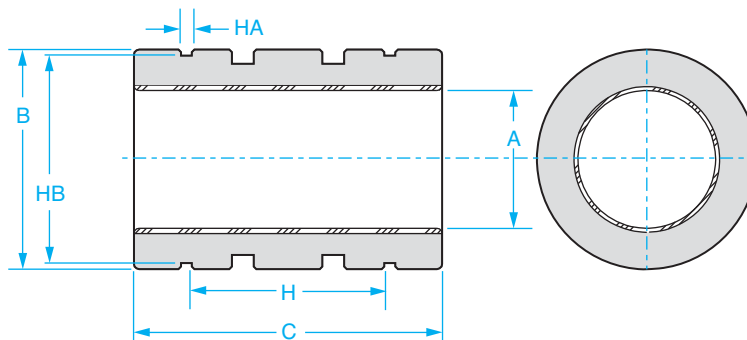

Référence Type	Dimensions - mm											Charges Statiques Static Load Max.	Poids Weight g
	Ø	A Diamètre intérieur Iner diameter		B Diamètre extérieur Outside diameter Tol h7		C Longueur Length Tol h13		Concentricité concentricity Max.	H	HA	HB		
		Min.	Max.	Min.	Max.	Min.	Max.					N	
FM 8	8	8,013	8,035	15,982	16	24,746	25	0,0254	14	1,14	15,2	4 120	9
FM 10	10	10,013	10,035	18,979	19	28,746	29	0,0254	19,4	1,32	18	5 984	14
FM 12	12	12,016	12,043	21,979	22	31,746	32	0,0254	20	1,32	21	7 907	17
FM 16	16	16,016	16,043	25,979	26	35,746	36	0,0254	22	1,32	24,9	11 870	28
FM 20	20	20,020	20,053	31,975	32	44,746	45	0,0254	28	1,63	30,3	18 541	54
FM 25	25	25,020	25,053	39,975	40	57,746	58	0,0254	40	1,90	37,5	29 881	109
FM 30	30	30,020	30,053	46,975	47	67,746	68	0,0254	48	1,90	44,5	42 026	176
FM 40	40	40,025	40,064	61,970	62	79,746	80	0,0254	56	2,20	59	65 923	356
FM 50	50	50,025	50,064	74,970	75	99,746	100	0,0254	72	2,70	72	103 005	628
FM 60	60	60,030	60,076	89,965	90	124,492	125	0,0380	95	3,20	86,4	154 508	1 117
FM 80	80	80,030	80,076	119,965	120	164,492	165	0,0510	125	4,17	116,1	271 933	2 679

Sans étanchéité

Without seals on both sides

Douille étanche ou graissable sur consultation

On request seals on both sides

Avantage : Température de fonctionnement -200 à +200°C Wide temperature range : -200°C at +200°C

Les douilles peuvent être montées dans les paliers : pages 94, 96, 104, 106, 107, 108, 110, 112.

